

GEP RCT - F POMPINSTALLATIES

Cascade speed controlled pump group with three pumps



rethinking water



PRODUCT DESCRIPTION

The RCT-F pumping systems from GEP are based on the high-quality self-priming GEP RC pumps, with built-in thermal protection and the GEP's F-speed pump control. These hydrophore sets are suitable for pressure boosting and rainwater use in industry and utilities, or can be used in all places where the water pressure needs to be increased and a constant comfortable water pressure is required.

SCOPE

Everywhere there is a need for a complete pre-assembled pump group with a relatively large pump capacity and a high operational reliability with a freely adjustable constant comfortable water pressure.

TECHNICAL DATA

Suction connection:	3 x 1 of 5/4" bi
Connection press:	6/4 of 2" bi
Length in mm:	900
Height in mm:	1100
Width in mm:	450
Max. RPM:	2.850

TECHNICAL SPECIFICATIONS

	RCT-3F	RCT-5F	RCT-8F	RCT-9F
Power in Watt:	3.300	4.050	4.950	6.000
Max. flow in liters / min:	120	160	450	480
Max. increaseHeight in m:	50	53	50	62
Weight in kg:	37	38	37	38
Temperature in ° C:	5-35	5-35	5-35	5-35
Capacitor in µF:	20	25	25	40
Number of fans:	5	5	4	5

TECHNICAL DRAWINGS

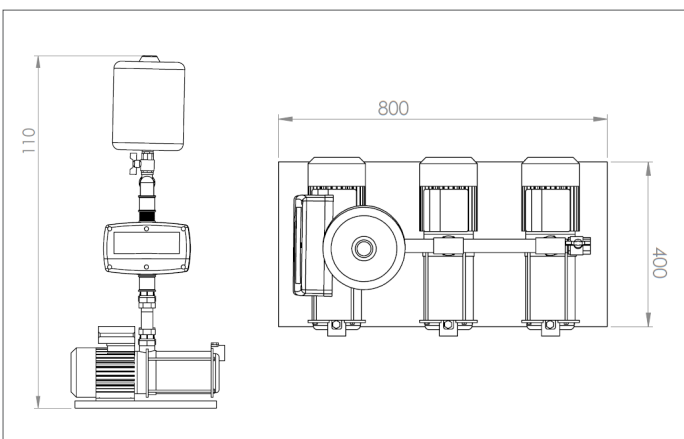

PUMP CHARACTERISTIC

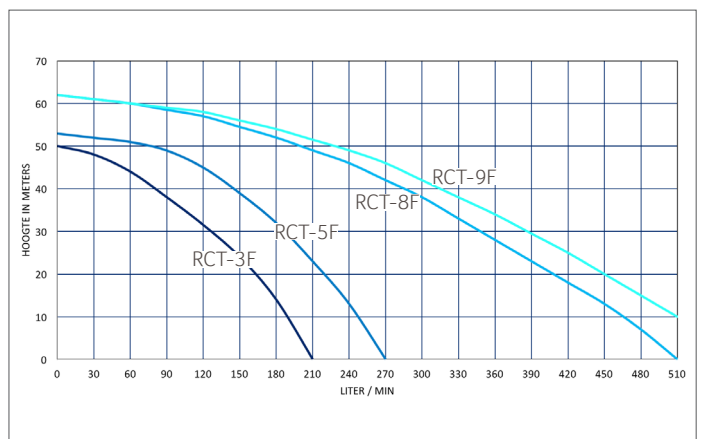

ORDERING INFORMATION

Art nr	NAME
402665	GEP RCT-3F pump group with 3 pumps and dry-running protection
402666	GEP RCT-5F pump group with 3 pumps and dry-running protection
402667	GEP RCT-8F pump group with 3 pumps and dry-running protection
402668	GEP RCT-9F pump group with 3 pumps and dry-running protection

PG

- 4
- 4
- 4
- 4

